

Caja de Unión

Cerradas y Selladas

RAWELT®



JB-0548-5



JB-0549-5



JB-0549

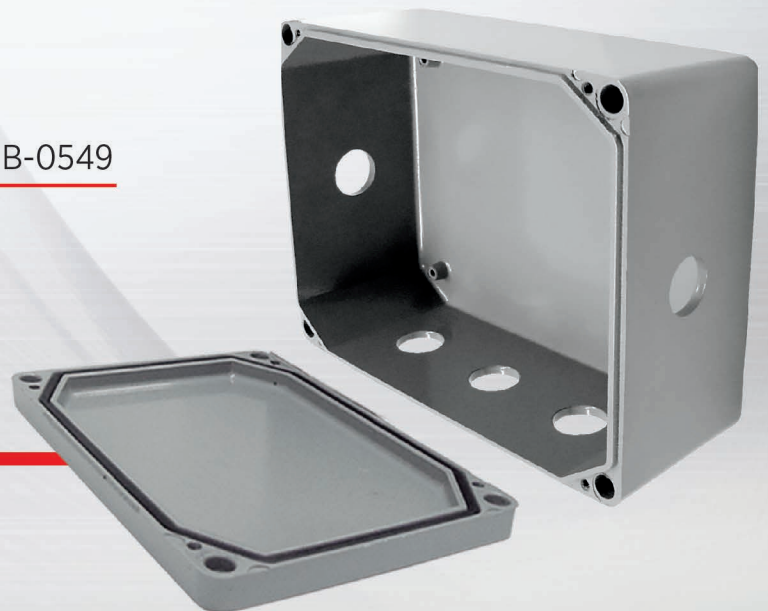

Junction Boxes
Enclosed and Gasketed.

**10.1 CAJA DE UNIÓN.
CERRADAS Y SELLADAS. SERIE JB.**

APLICACIONES:

Disñadas para contener instrumentos y controles o como caja de conexiones para componentes eléctricos, electrónicos o neumáticos en interiores y exteriores.

CONSTRUCCIÓN:

- Caja: Aluminio inyectado a presión (Diecast) NEMA 4/4X, IP66.
- Tornillos de acero inoxidable.
- Tornillo de tierra pasivado incluido.
- Tornillos de la tapa posicionados fuera del área de sellado.
- Agujeros de montaje localizados en las esquinas fuera del área de sellado.
- Arosello a prueba de humedad y aceite.
- Postes internos localizados para montaje opcional de paneles, rieles, tarjeta de conexiones y otros componentes.
- Acabados: Pintura electrostática epóxica/poliéster polimerizada.

ACCESORIOS OPCIONALES:

- Panel de aluminio 2 mm (0.080") espesor.
- Panel de acero Calibre 14. Pintura gris.
- Otras salidas pueden fabricarse previa consulta y presupuesto.

**10.1 JUNCTION BOXES.
ENCLOSED AND GASKETED. JB SERIES.**

APPLICATIONS:

Designed to housing instrument and controls or junction boxes to electrical, electronic or pneumatic components in outdoor and indoor.

CONSTRUCTION:

- Diecast aluminum 4/4X, IP66 enclosure.
- Stainless steel screws.
- Green ground screw included.
- Cover screws placed outside sealed area.
- Mounting holes provided in corners outside of gasketed area.
- Oil-resistant O-ring gasket with tongue and groove construction.
- Threaded internal bosses provided for mounting optional panels, rails, circuit boards and other components.
- Finish: Electrostatic powder epoxy/polyester coating.

OPTIONAL ACCESSORIES:

- Aluminum panels 0.080" (2 mm) thick.
- Steel panel 14 gauge. Gray finish.
- Other outlets can be ordered previous consult and quotation.

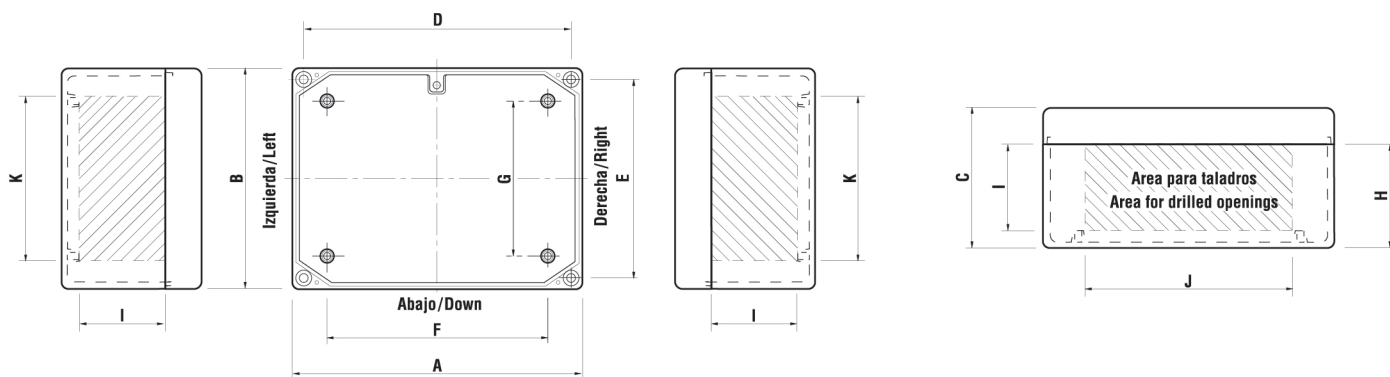

Código Code	Catálogo Catalog	Dimensiones / Dimensions																Área para taladros Area for drilled openings					
		A		B		C		D		E		F		G		H		I		J		K	
		mm	inch	mm	inch	mm	inch	mm	inch	mm	inch	mm	inch	mm	inch	mm	inch	mm	inch	mm	inch	mm	inch
25.01.0548	JB-0548	141	5.55	115	4.53	45	1.77	127.77	5.03	101.60	4.00	89.62	3.52	64.45	2.53	34.24	1.34	25.40	1.00	88.90	3.50	76.00	3.00
25.01.0549	JB-0549	210	8.27	156	6.14	100	3.94	193.45	7.61	140.64	5.53	160.11	6.30	108.76	4.28	75.52	2.97	63.50	2.5	152.40	6.00	104.00	4.09



Manufacturing and Integration 100% National.
Made in Mexico

RAWELT, S.A. de C.V.

Torreón, Coah., México
Tel: 871 747 47 84 / Ventas: 800 999 20 18
torreon@rawelt.com.mx



www.rawelt.com.mx



Serie JB Sección 10.1 | **RW47**

22-02

10.1 - CAJAS DE UNION. SERIE JB.
10.1 - JUNCTION BOXES. JB SERIES.

APLICACIONES:

Diseñadas para contener instrumentos y controles o como caja de conexiones para componentes eléctricos, electrónicos o neumáticos en interiores y exteriores.

CONSTRUCCION:

- Caja: aluminio inyectado a presión (diecast) NEMA 4/4X.
- Tornillos de acero inoxidable.
- Tornillo de tierra pasivado incluido
- Tornillos de la tapa posicionados fuera del área de sellado.
- Acabado: Pintura electrostática epóxica/poliéster polimerizada espesor mínimo de 2 mils
- Pruebas en cámara salina a pintura de acuerdo a ASTM B117
- Pruebas de adherencia a pintura de acuerdo a ASTM 3359
- Resistencia a impactos mecánicos en cuerpo de acuerdo a IK09, gracias a su diseño que no cuenta con elementos susceptibles a rompimiento.
- Agujeros de montaje localizados en las esquinas fuera del área de sellado.
- Arosello a prueba de humedad y aceite.
- Postes internos localizados para montaje opcional de paneles, rieles, tarjeta de conexiones y otros componentes.

ACCESORIOS OPCIONALES:

- Panel de aluminio 2 mm (0.080") espesor.
- Panel de acero Calibre 14. Pintura gris.
- Otras salidas pueden fabricarse previa consulta y presupuesto.

APPLICATIONS:

Designed to housing instrument and controls or junction boxes to electrical, electronic or pneumatic components in outdoor and indoor.

CONSTRUCTION:

- Diecast aluminum 4/4X enclosure.
- Stainless steel screws.
- Green ground screw included.
- Cover screws placed outside sealed area.
- Finish: Electrostatic powder coating epoxic/polyester. Minimum thickness 2 mils
- Saline chamber test to paint according to ASTM B117.
- Paint adhesion test according ASTM 3359.
- Resistance to mechanical impacts according IK09 body, thanks to its design that does not have elements susceptible to breakage.
- Mounting holes provided in corners outside of gasketed area.
- Oil-resistant O-ring gasket with tongue and groove construction.
- Threaded internal bosses provided for mounting optional panels, rails, circuit boards and other components.

OPTIONAL ACCESSORIES:

- Aluminum panels 0.080" (2mm) thick.
- Steel panel 14 gauge. Gray finish.
- Other outlets can be ordered previous consult and quotation.

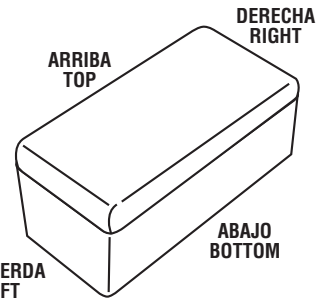

Para dimensiones:

Ver Ficha Tecnica 007-RW-201.

For dimensions:

See Technical Data 007-RW-201.

USAR No. DE CODIGO PARA HACER PEDIDOS. TO ORDER USE CODE NUMBER.

Item	Figura Figure	Salidas Outlets	Salidas Drilled openings		Catalogo Catalog	Codigo Code	Peso x 100 pzas. Weight x 100 pcs.		Std. Pkg. Pzas. Pcs.
			mm	inch			kg	Lb	
1		Sin taladros Blank			JB-0548	25.01.0548	58.5	128.7	24
2		Izquierda/Left 2 Derecha/Right 2 Abajo/Bottom 1	12.7	1/2	JB-0548-51	25.01.3049.13	57.0	125.4	24
			15.8	5/8	JB-0548-52	25.01.3049.16			
			19.0	3/4	JB-0548-53	25.01.3049.19			
3		Sin taladros Blank			JB-0549	25.01.0549	161.0	354.2	4
4		Abajo/Bottom 3	19.0	3/4	JB-0549-31	25.01.3050.19	160.0	352.0	4
			22.2	7/8	JB-0549-32	25.01.3050.22			
			25.4	1	JB-0549-33	25.01.3050.25			

Especificaciones sujetas a cambio sin previo aviso. Specifications are subject to change without notice.

10.1 - CAJAS DE UNION. SERIE JB.
10.1 - JUNCTION BOXES. JB SERIES.

Hoja: 2 / 2
 Page:

FICHA TECNICA / TECHNICAL DATA

007-RW-238

USAR No. DE CODIGO PARA HACER PEDIDOS. TO ORDER USE CODE NUMBER.

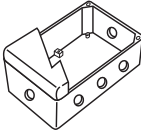
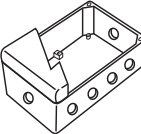
Item	Figura Figure	Salidas Outlets	Salidas Drilled openings		Catalogo Catalog	Codigo Code	Peso x 100 pzas. Weight x 100 pcs.		Std. Pkg. Pzas. Pcs.
			mm	inch			kg	Lb	
5		Izquierda/Left 1	19.0	3/4	JB-0549-51	25.01.3051.19	159.0	349.8	4
		Derecha/Right 1	22.22	7/8	JB-0549-52	25.01.3051.22			
		Abajo/Bottom 3	25.4	1	JB-0549-53	25.01.3051.25			
6		Izquierda/Left 1	19.0	3/4	JB-0549-61	25.01.3052.19	158.0	347.6	4
		Derecha/Right 1	22.22	7/8	JB-0549-62	25.01.3052.22			
		Abajo/Bottom 4	25.4	1	JB-0549-63	25.01.3052.25			

ACCESORIO

PANEL

- Para cajas de unión codigos: 0548 y 3049
- 4 tornillos de acero inoxidable incluidos.

ACCESSORY

PANEL

- For junction boxes codes: 0548 and 3049
- 4 stainless steel screws included.

Dimensiones en milímetros y en pulgadas.
 Dimensions in inches and millimeters.

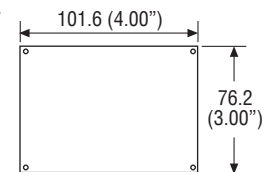

USAR No. DE CODIGO PARA HACER PEDIDOS. TO ORDER USE CODE NUMBER.

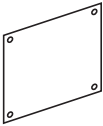
Item	Figura Figure	Descripción Description	Catalogo Catalog	Codigo Code	Peso x 100 pzas. Weight x 100 pcs.		Pqt. Unit Pzas. Pcs.	Unit. Ctn. Pzas. Pcs.	Std. Pkg. Pzas. Pcs.
					kg	Lb			
7		Panel JB de acero Cal. 14. Pintura gris JB steel panel. 14 gauge. Gray finish.	PJB-0548-S	25.02.3368			10		
8		Panel JB de aluminio. 2 mm. JB aluminum panel. 0.080 ".	PJB-0548-A	25.02.3369			10		
9		Panel JB de acero inoxidable Cal. 14. JB stainless steel panel. 14 gauge.	PJB-0548-SS	25.02.3372			10		

ACCESORIO

PANEL

- Para cajas de unión codigos: 0549, 3050, 3051 y 3052.
- 4 tornillos de acero inoxidable incluidos.

ACCESSORY

PANEL

- For junction boxes codes: 0549, 3050, 3051 and 3052.
- 4 stainless steel screws included.

Dimensiones en milímetros y en pulgadas.
 Dimensions in inches and millimeters.

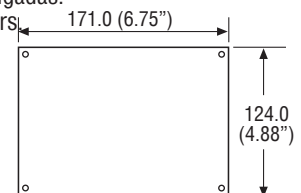

USAR No. DE CODIGO PARA HACER PEDIDOS. TO ORDER USE CODE NUMBER.

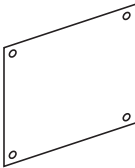
Item	Figura Figure	Descripción Description	Catalogo Catalog	Codigo Code	Peso x 100 pzas. Weight x 100 pcs.		Pqt. Unit Pzas. Pcs.	Unit. Ctn. Pzas. Pcs.	Std. Pkg. Pzas. Pcs.
					kg	Lb			
10		Panel JB de acero Cal. 14. Pintura gris JB steel panel. 14 gauge. Gray finish.	PJB-0549-S	25.02.3370			10		
11		Panel JB de aluminio. 2 mm. JB aluminum panel. 0.080 ".	PJB-0549-A	25.02.3371			10		
12		Panel JB de acero inoxidable Cal. 14. JB stainless steel panel. 14 gauge.	PJB-0549-SS	25.02.3373			10		

Especificaciones sujetas a cambio sin previo aviso. Specifications are subject to change without notice.

RAWELT, S.A. de C.V.

RAWELT® INYECTADOS
 Una División del Grupo REVUELTA

10.1 - CAJAS DE UNION. SERIE JB.

10.1 - JUNCTION BOXES. JB SERIES.

Hoja: 1 / 1
Page:

FICHA TECNICA / TECHNICAL DATA

007-RW-201

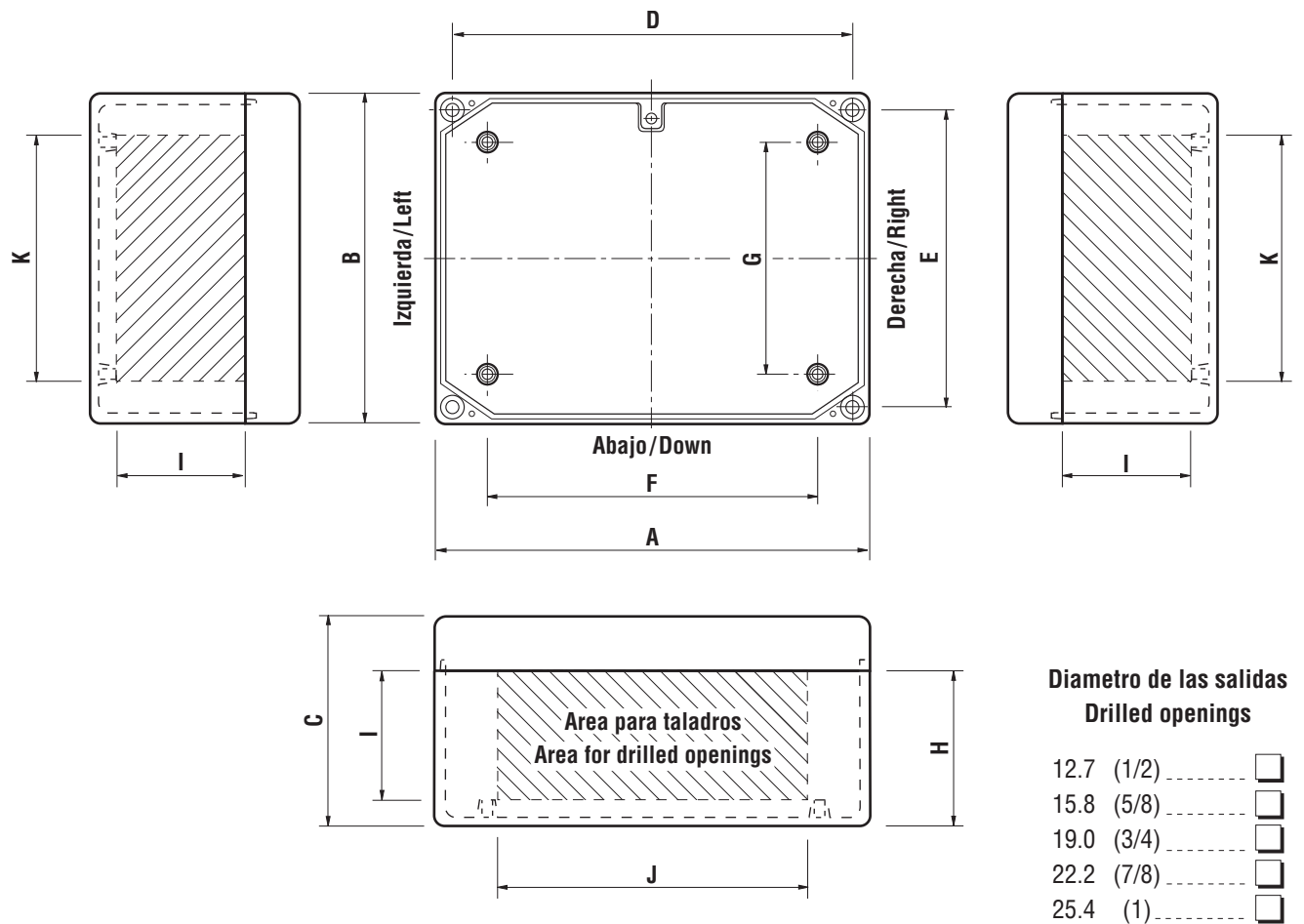

Código Code	Catalogo Catalog	Dimensiones / Dimentions																Area para taladros Area for drilled openings					
		A		B		C		D		E		F		G		H		I		J		K	
		mm	inch	mm	inch	mm	inch	mm	inch	mm	inch	mm	inch	mm	inch	mm	inch	mm	inch	mm	inch	mm	inch
25.01.0548	JB-0548	141	5.55	115	4.53	45	1.77	127.77	5.03	101.60	4.00	89.62	3.52	64.45	2.53	34.24	1.34	25.40	1.00	88.90	3.50	76.00	3.00
25.01.0549	JB-0549	210	8.27	156	6.14	100	3.94	193.45	7.61	140.64	5.53	160.11	6.30	108.76	4.28	75.52	2.97	63.50	2.5	152.40	6.00	104.00	4.09

Especificaciones sujetas a cambio sin previo aviso.

Specifications are subject to change without notice.

RAWELT, S.A. de C.V.

RAWELT® INYECTADOS
Una División del Grupo REVUELTA

Cotización/Quotation Plazo de embarque* / Shipment exw* :

 Pedido No./Purchase order : _____

Our ref.: _____

Fecha/Date: _____ Vendedor/Salesman: _____ No. _____

Facturar a/Invoice to: _____ RFC: _____

Ordenado por/Ordered by: _____ Tel. () _____ Fax () _____

Dirección/Address: _____

C.P./Zip: _____ Lugar/City/Country: _____

Consignar a/Ship to: _____

 Embarcar: Camión x Cobrar Pagado Paquete

Cond. de Pago/Terms: _____

Cond. de Venta/Sale conditions: _____ L.P.: _____

 • Antes de fincar el pedido en firme, favor de confirmar con fábrica el plazo de embarque definitivo.
 • Before place your order, please confirm with RAWELT definitive date of shipment.

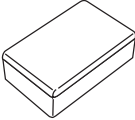
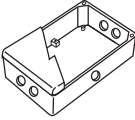
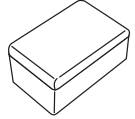
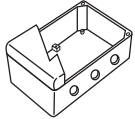
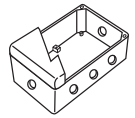
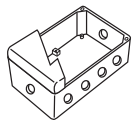
10.1.- SERIE JB. CAJAS DE UNION / JUNCTION BOXES.							
Item. No.	Figura Figure	Salidas Outlets	Salidas Drilled openings		Código Code	Std. Pkg. Pzas. Pcs.	Cantidad Qty.
			mm	inch			
1		Sin Salidas Blank			25.01.0548	24	
2		Izquierda/Left 2 Derecha/Right 2 Abajo/Bottom 1	12.7	1/2	25.01.3049.13	24	
			15.8	5/8	25.01.3049.16		
			19.0	3/4	25.01.3049.19		
3		Sin Salidas Blank			25.01.0549	4	
4		Abajo/Bottom 3	19.0	3/4	25.01.3050.19	4	
			22.2	7/8	25.01.3050.22		
			25.4	1	25.01.3050.25		
5		Izquierda/Left 1 Derecha/Right 1 Abajo/Bottom 3	19.0	3/4	25.01.3051.19	4	
			22.2	7/8	25.01.3051.22		
			25.4	1	25.01.3051.25		
6		Izquierda/Left 1 Derecha/Right 1 Abajo/Bottom 4	19.0	3/4	25.01.3052.19	4	
			22.2	7/8	25.01.3052.22		
			25.4	1	25.01.3052.25		

 Expediente
 Control
 Embarques
 Almacén
 Producción

**10.3 - CAJAS DE UNION. SERIE JB
CON RECUBRIMIENTO EXTERIOR DE PVC E INTERIOR DE URETANO PURPURA**

Hoja: 1 / 3
Page:

**10.3 - JUNCTION BOXES. JB SERIES.
WITH PVC COATING AND PURPLE URETHANE INNER COATING**

**FICHA TECNICA / TECHNICAL DATA
007-RW-405**

APLICACIONES:

Diseñadas para contener instrumentos y controles o como caja de conexiones para componentes electricos, electrónicos o neumáticos en interiores y exteriores.

CONSTRUCCION:

- Caja: aluminio inyectado a presión (diecast) NEMA 4/4X.
- Tornillos de acero inoxidable.
- Tornillo de tierra pasivado incluido
- Tornillos de la tapa posicionados fuera del área de sellado.
- Acabado: Pintura electrostática epóxica/poliéster polimerizada espesor mínimo de 2 mils
- Pruebas en cámara salina a pintura de acuerdo a ASTM B117
- Pruebas de adherencia a pintura de acuerdo a ASTM 3359
- Resistencia a impactos mecánicos en cuerpo de acuerdo a IK09, gracias a su diseño que no cuenta con elementos susceptibles a rompimiento.
- Agujeros de montaje localizados en las esquinas fuera del área de sellado.
- Arosello a prueba de humedad y aceite.
- Postes internos localizados para montaje opcional de paneles, rieles, tarjeta de conexiones y otros componentes.

ACCESORIOS OPCIONALES:

- Panel de aluminio 2 mm (0.080") espesor.
- Panel de acero Calibre 14. Pintura gris.
- Otras salidas pueden fabricarse previa consulta y presupuesto.

- A prueba de áreas corrosivas.
- Recubrimiento: PVC 40 mils mínimo.
- Uretano PURPURA: 2 mils mínimo.
- Mangas en las entradas para un sellado hermético.
- Material: Aluminio inyectado a presión (diecast).
- Pruebas de cámara salina de acuerdo a ASTM B117
- Pruebas de adherencia de acuerdo a ASTM 3359
- Resistencia a impactos mecánicos en cuerpo de acuerdo a IK09, gracias a que no cuenta con elementos susceptibles a rompimiento
- Rosca NPT para usarse con tubo conduit RIGIDO e IMC.
- Dos tornillos de tierra pasivados incluidos.
- A prueba de intemperie.
- Profundidad de 67 mm en caja de rosca 25.4 (1"), y profundidad 50.8 mm (2") en cajas de rosca 12.7 y 19.0 (1/2" y 3/4")

APLICACIONES:

- Pueden ser instaladas para recibir accesorios como: Interruptores, contactos, estaciones de botones, luces piloto.
- Sirven para hacer empalmes y conexiones en el cableado. Permite facil acceso para mantenimiento.
- Fabricación en base a: UL 514 A, UL 514 B
CAN/CSA-C22.2 No. 18-92
NEMA RN-1

APPLICATIONS:

Designed to housing instrument and controls or junction boxes to electrical, electronic or pneumatic components in outdoor and indoor.

CONSTRUCTION:

- Diecast aluminum 4/4X enclosure.
- Stainless steel screws.
- Green ground screw included.
- Cover screws placed outside sealed area.
- Finish: Electrostatic powder coating epoxic/polyester. Minimum thickness 2 mils
- Saline chamber test to paint according to ASTM B117.
- Paint adhesion test according ASTM 3359.
- Resistance to mechanical impacts according IK09 body, thanks to its design that does not have elements susceptible to breakage.
- Mounting holes provided in corners outside of gasketed area.
- Oil-resistant O-ring gasket with tongue and groove construction.
- Threaded internal bosses provided for mounting optional panels, rails, circuit boards and other components.

OPTIONAL ACCESSORIES:

- Aluminum panels 0.080" (2mm) thick.
- Steel panel 14 gauge. Gray finish.
- Other outlets can be ordered previous consult and quotation.

- PVC coating: 40 mils minimum.
- PVC coating: 40 mils minimum.
- PURPLE Urethane: Interior protection: 2 mils minimum.
- Pressure sealing sleeves on conduit openings.
- Material: Diecast aluminum.
- Saline chamber test according to ASTM B117
- Paint adhesion test according to ASTM 3359
- Resistance to mechanicals impacts to body according IK09, thanks to its design that does not have elements susceptible to breakage
- Two green ground screws included.
- For wet location.
- NPT threaded for use with RIGID and IMC conduit.
- Box 1" (25.4 mm) of 2 5/8" Depth. Boxes 1/2" and 3/4", 2" Depth.

APPLICATIONS:

- They can be installed to accommodate accessories such as switches, receptacles.
- Provide openings for making splice and taps. Allow access for maintenance.
- Manufactured in compliance with: UL 514 A, UL 514 B
CAN/CSA-C22.2 No. 18-92
NEMA RN-1

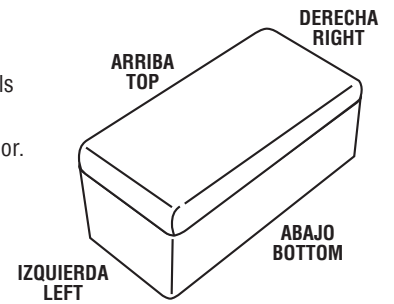

Para dimensiones:
Ver Ficha Tecnica 007-RW-201.

For dimensions:
See Technical Data 007-RW-201.

Especificaciones sujetas a cambio sin previo aviso. Specifications are subject to change without notice.

RAWELT, S.A. de C.V.

RAWELT
PURPURA COAT

10.3 - CAJAS DE UNION. SERIE JB
CON RECUBRIMIENTO EXTERIOR DE PVC E INTERIOR DE URETANO PURPURA

Hoja: 2 / 3
 Page:

10.3 - JUNCTION BOXES. JB SERIES.
WITH PVC COATING AND PURPLE URETHANE INNER COATING

FICHA TECNICA / TECHNICAL DATA
007-RW-405

USAR No. DE CODIGO PARA HACER PEDIDOS. TO ORDER USE CODE NUMBER.

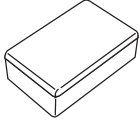
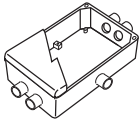
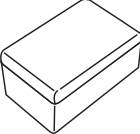
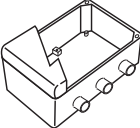
Item	Figura Figure	Salidas Outlets	Salidas Drilled openings		Catalogo Catalog	Codigo Code	Peso x 100 pzas. Weight x 100 pcs.		Std. Pkg. Pzas. Pcs.
			mm	inch			kg	Lb	
1		Sin taladros Blank			JB-0548-PC	25.04.5450.PC	70	154	
2		Izquierda/Left 2 Derecha/Right 2 Abajo/Bottom 1	12.7	1/2	JB-0548-51-PC	25.04.5451.PC	70	154	
			15.8	5/8	JB-0548-52-PC	25.04.5452.PC			
			19.0	3/4	JB-0548-53-PC	25.04.5453.PC			
3		Sin taladros Blank			JB-0549-PC	25.04.3642.PC	193	232	
4		Abajo/Bottom 3	19.0	3/4	JB-0549-31-PC	25.04.5454.PC	193	232	
			22.2	7/8	JB-0549-32-PC	25.04.5455.PC			
			25.4	1	JB-0549-33-PC	25.04.5456.PC			

USAR No. DE CODIGO PARA HACER PEDIDOS. TO ORDER USE CODE NUMBER.

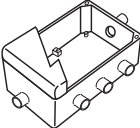
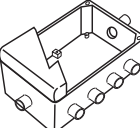
Item	Figura Figure	Salidas Outlets	Salidas Drilled openings		Catalogo Catalog	Codigo Code	Peso x 100 pzas. Weight x 100 pcs.		Std. Pkg. Pzas. Pcs.
			mm	inch			kg	Lb	
5		Izquierda/Left 1 Derecha/Right 1 Abajo/Bottom 3	19.0	3/4	JB-0549-51-PC	25.04.5457.PC	191	420	
			22.22	7/8	JB-0549-52-PC	25.04.5458.PC			
			25.4	1	JB-0549-53-PC	25.04.5459.PC			
6		Izquierda/Left 1 Derecha/Right 1 Abajo/Bottom 4	19.0	3/4	JB-0549-61-PC	25.04.5460.PC	191	420	
			22.22	7/8	JB-0549-62-PC	25.04.5461.PC			
			25.4	1	JB-0549-63-PC	25.04.5462.PC			

ACCESORIO

PANEL

- Para cajas de unión codigos: 0548 y 3049
- 4 tornillos de acero inoxidable incluidos.

ACCESSORY

PANEL

- For junction boxes codes: 0548 and 3049
- 4 stainless steel screws included.

Dimensiones en milímetros y en pulgadas.
 Dimensions in inches and millimeters.

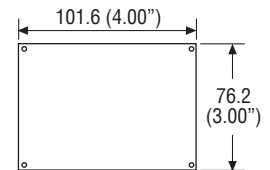

RAWELT, S.A. de C.V.

RAWELT
PURPURA COAT

10.3 - CAJAS DE UNION. SERIE JB
CON RECUBRIMIENTO EXTERIOR DE PVC E INTERIOR DE URETANO PURPURA

10.3 - JUNCTION BOXES. JB SERIES.
WITH PVC COATING AND PURPLE URETHANE INNER COATING

FICHA TECNICA / TECHNICAL DATA

007-RW-405

USAR No. DE CODIGO PARA HACER PEDIDOS. TO ORDER USE CODE NUMBER.

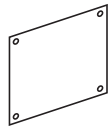
Item	Figura Figure	Descripción Description	Catalogo Catalog	Codigo Code	Peso x 100 pzas. Weight x 100 pcs.		Pqt. Unit Pzas. Pcs.	Unit. Ctn. Pzas. Pcs.	Std. Pkg. Pzas. Pcs.
					kg	Lb			
7		Panel JB de acero Cal. 14. Pintura gris JB steel panel. 14 gauge. Gray finish.	PJB-0548-S	25.02.3368			10		
8		Panel JB de aluminio. 2 mm. JB aluminum panel. 0.080 ".	PJB-0548-A	25.02.3369			10		
9		Panel JB de acero inoxidable Cal. 14. JB stainless steel panel. 14 gauge.	PJB-0548-SS	25.02.3372			10		

ACCESORIO

PANEL

- Para cajas de unión
codigos: 0549, 3050, 3051 y 3052.
- 4 tornillos de acero inoxidable incluidos.

ACCESSORY

PANEL

- For junction boxes
codes: 0549, 3050, 3051 and 3052.
- 4 stainless steel screws included.

Dimensiones en milímetros y en pulgadas.
Dimensions in inches and millimeters.

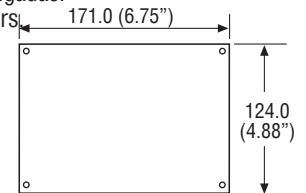

USAR No. DE CODIGO PARA HACER PEDIDOS. TO ORDER USE CODE NUMBER.

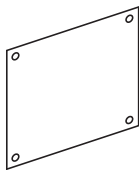
Item	Figura Figure	Descripción Description	Catalogo Catalog	Codigo Code	Peso x 100 pzas. Weight x 100 pcs.		Pqt. Unit Pzas. Pcs.	Unit. Ctn. Pzas. Pcs.	Std. Pkg. Pzas. Pcs.
					kg	Lb			
10		Panel JB de acero Cal. 14. Pintura gris JB steel panel. 14 gauge. Gray finish.	PJB-0549-S	25.02.3370			10		
11		Panel JB de aluminio. 2 mm. JB aluminum panel. 0.080 ".	PJB-0549-A	25.02.3371			10		
12		Panel JB de acero inoxidable Cal. 14. JB stainless steel panel. 14 gauge.	PJB-0549-SS	25.02.3373			10		

Especificaciones sujetas a cambio sin previo aviso. Specifications are subject to change without notice.

RAWELT, S.A. de C.V.

RAWELT
PURPURA COAT

Cotización/Quotation Plazo de embarque* / Shipment exw* :

Pedido No./Purchase order :

Our ref.:

Fecha/Date: Vendedor/Salesman: No.

Facturar a/Invoice to: RFC:

Ordenado por/Ordered by: Tel. () Fax ()

Dirección/Address:

C.P./Zip: Lugar/City/Country:

Consignar a/Ship to:

Embarcar: Camión x Cobrar Pagado Paquete

Cond. de Pago/Terms:

Cond. de Venta/Sale conditions: L.P.:

• Antes de fincar el pedido en firme, favor de confirmar con fábrica el plazo de embarque definitivo.
 • Before place your order, please confirm with RAWELT definitive date of shipment.

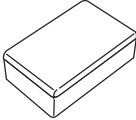
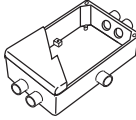
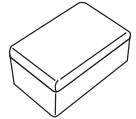
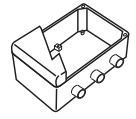
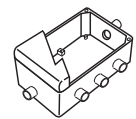
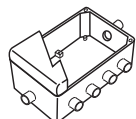
10.3.- SERIE JB. CAJAS DE UNION / JUNCTION BOXES. PVC							
Item. No.	Figura Figure	Salidas Outlets	Salidas Drilled openings		Código Code	Std. Pkg. Pzas. Pcs.	Cantidad Qty.
			mm	inch			
1		Sin Salidas Blank			25.04.5450.PC		
2		Izquierda/Left 2 Derecha/Right 2 Abajo/Bottom 1	12.7	1/2	25.04.5451PC		
			15.8	5/8	25.04.5452.PC		
			19.0	3/4	25.04.5453.PC		
3		Sin Salidas Blank			25.04.3642.PC		
4		Abajo/Bottom 3	19.0	3/4	25.04.5454.PC		
			22.2	7/8	25.04.5455.PC		
			25.4	1	25.04.5456.PC		
5		Izquierda/Left 1 Derecha/Right 1 Abajo/Bottom 3	19.0	3/4	25.04.5457.PC		
			22.2	7/8	25.04.5458.PC		
			25.4	1	25.04.5459.PC		
6		Izquierda/Left 1 Derecha/Right 1 Abajo/Bottom 4	19.0	3/4	25.04.5460.PC		
			22.2	7/8	25.04.5461.PC		
			25.4	1	25.04.5462.PC		

Expediente
 Control
 Embarques
 Almacén
 Producción